

Please check the examination details below before entering your candidate information

Candidate surname

Other names

**Pearson Edexcel**  
**International**  
**Advanced Level**

Centre Number

--	--	--	--	--

Candidate Number

--	--	--	--	--

**Monday 20 May 2019**

Morning (Time: 1 hour 30 minutes)

Paper Reference **WCH11/01**

**Chemistry**

**International Advanced Subsidiary/Advanced Level**

**Unit 1: Structure, Bonding and Introduction to  
Organic Chemistry**

**Candidates must have: Scientific calculator  
Ruler**

Total Marks

### Instructions

- Use **black** ink or **black** ball-point pen.
- **Fill in the boxes** at the top of this page with your name, centre number and candidate number.
- Answer **all** questions.
- Answer the questions in the spaces provided  
– *there may be more space than you need.*

### Information

- The total mark for this paper is 80.
- The marks for **each** question are shown in brackets  
– *use this as a guide as to how much time to spend on each question.*
- You will be assessed on your ability to organise and present information, ideas, descriptions and arguments clearly and logically, including your use of grammar, punctuation and spelling.
- There is a Periodic Table on the back page of this paper.

### Advice

- Read each question carefully before you start to answer it.
- Show all your working in calculations and include units where appropriate.
- Check your answers if you have time at the end.

Turn over ►

P61476A

©2019 Pearson Education Ltd.

2/1/1/1/



  
Pearson

## SECTION A

Answer **ALL** the questions in this section.

You should aim to spend no more than 20 minutes on this section.

For each question, select one answer from A to D and put a cross in the box ☒.  
If you change your mind, put a line through the box ~~☒~~ and then mark your new answer with a cross ☒.

- 1 Which statement is **not** true for sodium chloride?
- A sodium chloride conducts electricity in aqueous solution
  - B sodium chloride conducts electricity when molten
  - C sodium chloride has a molecular structure
  - D sodium chloride has a giant structure

(Total for Question 1 = 1 mark)

- 2 Which of these molecules is the **most** polar?

- A H—H
- B H—F
- C H—Cl
- D H—Br

(Total for Question 2 = 1 mark)

- 3 Covalent bonding is best described as the electrostatic attraction between

- A oppositely charged ions
- B positive ions and delocalised electrons
- C a shared pair of electrons
- D two nuclei and a shared pair of electrons

(Total for Question 3 = 1 mark)

Use this space for any rough working. Anything you write in this space will gain no credit.

DO NOT WRITE IN THIS AREA

DO NOT WRITE IN THIS AREA

DO NOT WRITE IN THIS AREA



4 Which is correct for tetrafluoromethane (CF<sub>4</sub>)?

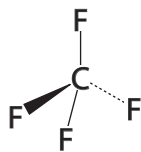

	Bonds	Molecule
<input type="checkbox"/> A	polar	polar
<input type="checkbox"/> B	non-polar	polar
<input type="checkbox"/> C	polar	non-polar
<input type="checkbox"/> D	non-polar	non-polar

(Total for Question 4 = 1 mark)

5 Which pair of ions gives the strongest ionic bonding?

- A Na<sup>+</sup> and F<sup>-</sup>
- B K<sup>+</sup> and Br<sup>-</sup>
- C Mg<sup>2+</sup> and O<sup>2-</sup>
- D Ca<sup>2+</sup> and S<sup>2-</sup>

(Total for Question 5 = 1 mark)

Use this space for any rough working. Anything you write in this space will gain no credit.



6 In 1.31 g of a chloride of titanium, there is 0.528 g of titanium.

What is the empirical formula of this titanium chloride?

[  $A_r$  values: Ti = 47.9 Cl = 35.5 ]

- A TiCl
- B TiCl<sub>2</sub>
- C TiCl<sub>3</sub>
- D Ti<sub>2</sub>Cl<sub>4</sub>

(Total for Question 6 = 1 mark)

7 Which isotope is used as the standard in the definition of relative atomic mass?

- A <sup>1</sup>H
- B <sup>12</sup>C
- C <sup>13</sup>C
- D <sup>16</sup>O

(Total for Question 7 = 1 mark)

8 Which statement about subatomic particles is correct?

- A neutral atoms always contain the same number of protons and electrons
- B neutral atoms always contain the same number of protons and neutrons
- C electrons have a relative mass of 1 and a charge of -1
- D protons have a relative mass of 1 and no charge

(Total for Question 8 = 1 mark)

Use this space for any rough working. Anything you write in this space will gain no credit.



DO NOT WRITE IN THIS AREA

DO NOT WRITE IN THIS AREA

DO NOT WRITE IN THIS AREA

9 Which sketch graph shows the trend in first ionisation energy values going down Group 1 in the Periodic Table?

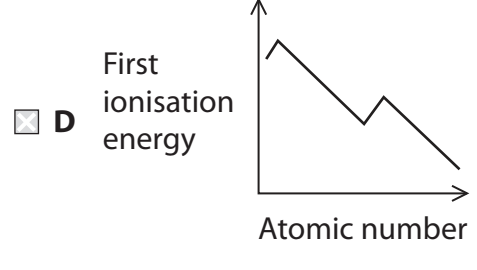
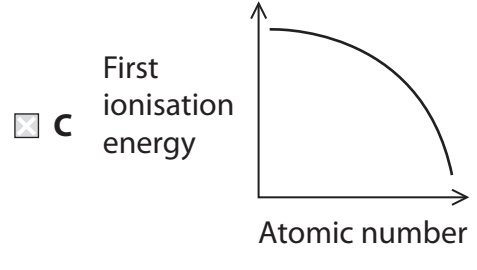
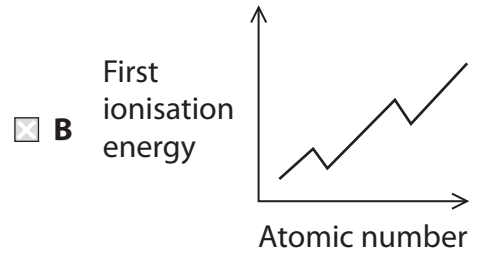
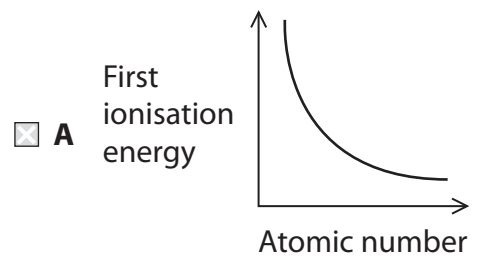

(Total for Question 9 = 1 mark)

Use this space for any rough working. Anything you write in this space will gain no credit.



10 Isotopes are atoms of an element that have different

- A electronic structures
- B numbers of electrons
- C numbers of protons
- D numbers of neutrons

(Total for Question 10 = 1 mark)

11 The two stable isotopes of bromine have relative masses of 79 and 81.

Which is the correct pattern of peaks in the mass spectrum of molecular bromine?

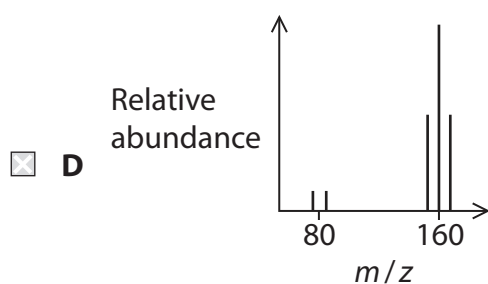
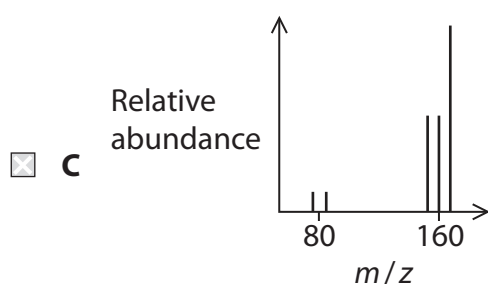
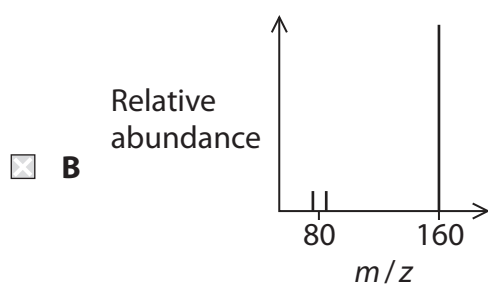
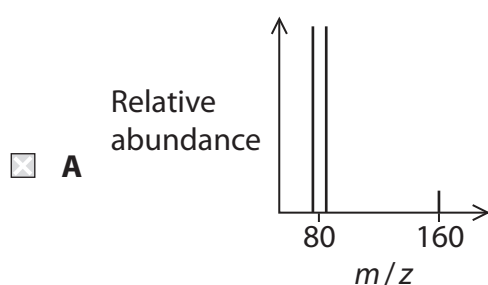

(Total for Question 11 = 1 mark)



12 The mass spectrum of a sample of silicon is shown.

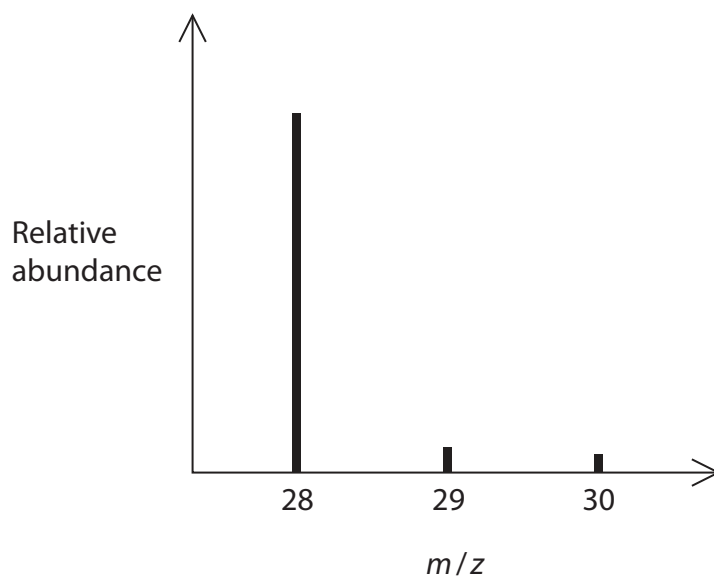

What is the **best** estimate for the relative atomic mass of silicon in this sample?

- A 28.0
- B 28.2
- C 28.8
- D 29.0

(Total for Question 12 = 1 mark)

13 Which is the equation for the **second** ionisation energy of an element, A?

- A  $A(g) \rightarrow A^{2+}(g) + 2e^{-}$
- B  $A^{+}(g) \rightarrow A^{2+}(g) + e^{-}$
- C  $A^{2+}(g) \rightarrow A^{3+}(g) + e^{-}$
- D  $A^{2+}(g) \rightarrow A^{4+}(g) + 2e^{-}$

(Total for Question 13 = 1 mark)

Use this space for any rough working. Anything you write in this space will gain no credit.



14 The bar chart shows the melting temperatures of the first twenty elements.

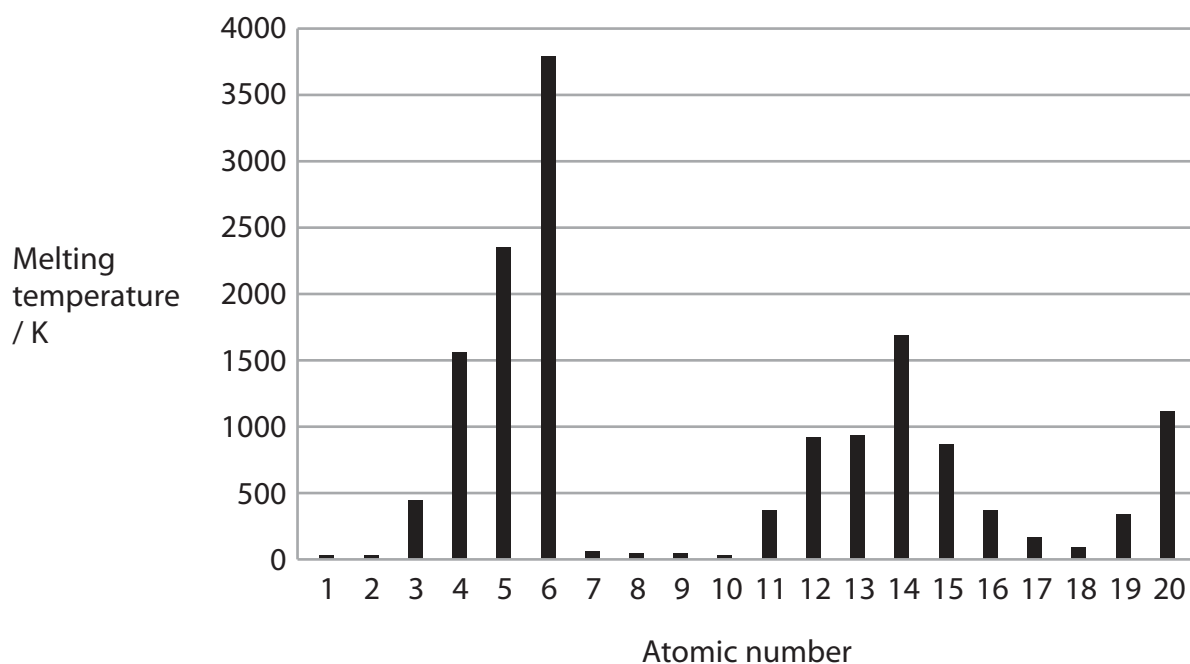

The bar chart shows that melting temperatures

- A of giant covalent structures are the highest in Period 2 and in Period 3
- B of metals are always higher than non-metals
- C increase going down each group
- D increase across Period 2 and Period 3

(Total for Question 14 = 1 mark)

Use this space for any rough working. Anything you write in this space will gain no credit.





15 Which is the electronic configuration of the  $\text{Sc}^{3+}$  ion?

- A  $1s^2 2s^2 2p^6 3s^2 3p^6$   
 B  $1s^2 2s^2 2p^6 3s^2 3p^5 3d^1$   
 C  $1s^2 2s^2 2p^6 3s^2 3p^6 3d^1 4s^2$   
 D  $1s^2 2s^2 2p^6 3s^2 3p^6 3d^4 4s^2$

(Total for Question 15 = 1 mark)

16 What is the name of the product when this molecule reacts with chlorine gas?

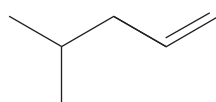

- A 5,5-dichloro-2-methylpentane  
 B 4,5-dichloro-2-methylpentane  
 C 2,3-dichloro-4-methylpentane  
 D 1,2-dichloro-4-methylpentane

(Total for Question 16 = 1 mark)

17 What type of bond breaking occurs in this process?



- A electrophilic  
 B heterolytic  
 C homolytic  
 D ionic

(Total for Question 17 = 1 mark)

Use this space for any rough working. Anything you write in this space will gain no credit.



18 What reagent and conditions are used for this conversion?

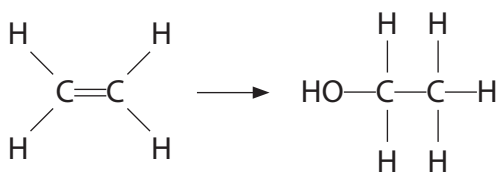

- A potassium manganate(VII) in aqueous acid
- B sodium hydroxide in dilute aqueous solution
- C steam and acid catalyst
- D steam and nickel catalyst

(Total for Question 18 = 1 mark)

19 But-2-ene shows geometric isomerism.

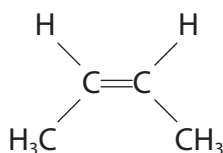

What are the prefixes that could be used in naming this isomer?

	<i>cis / trans</i>	<i>E / Z</i>
<input type="checkbox"/> A	<i>cis</i>	<i>E</i>
<input type="checkbox"/> B	<i>cis</i>	<i>Z</i>
<input type="checkbox"/> C	<i>trans</i>	<i>E</i>
<input type="checkbox"/> D	<i>trans</i>	<i>Z</i>

(Total for Question 19 = 1 mark)



DO NOT WRITE IN THIS AREA

DO NOT WRITE IN THIS AREA

DO NOT WRITE IN THIS AREA

20 Which is the major product of this reaction?

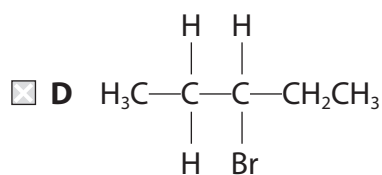
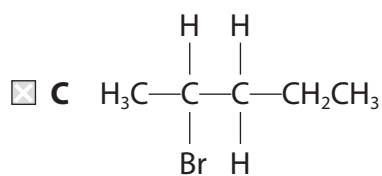
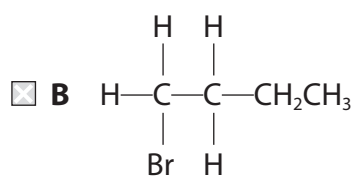
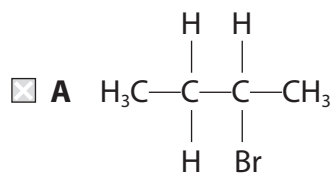
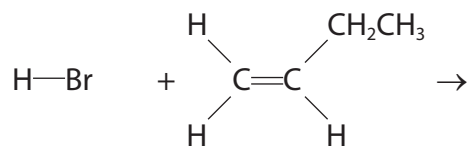

(Total for Question 20 = 1 mark)

TOTAL FOR SECTION A = 20 MARKS



## SECTION B

Answer ALL the questions. Write your answers in the spaces provided.

21 Magnesium carbonate powder reacts with hydrochloric acid.

(a) Complete the equation for this reaction by adding state symbols.

(1)



(b) A student carried out an investigation to determine the molar volume of carbon dioxide using this apparatus.

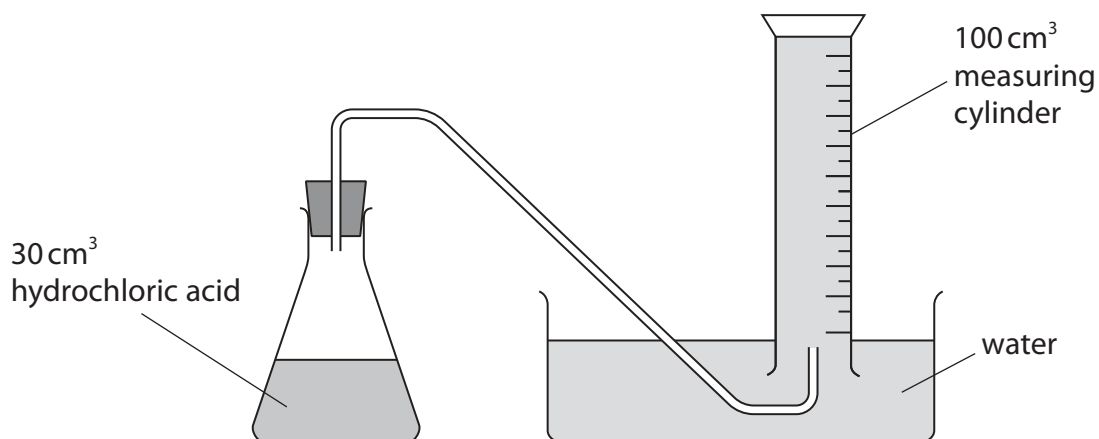

The student carried out five experiments, adding a different mass of magnesium carbonate each time.

The results are shown in the table.

Mass of magnesium carbonate / g	Volume of gas collected / cm <sup>3</sup>
0.05	11
0.10	27
0.15	38
0.20	54
0.25	63

DO NOT WRITE IN THIS AREA

DO NOT WRITE IN THIS AREA

DO NOT WRITE IN THIS AREA



(i) Plot a graph of these results.

(3)

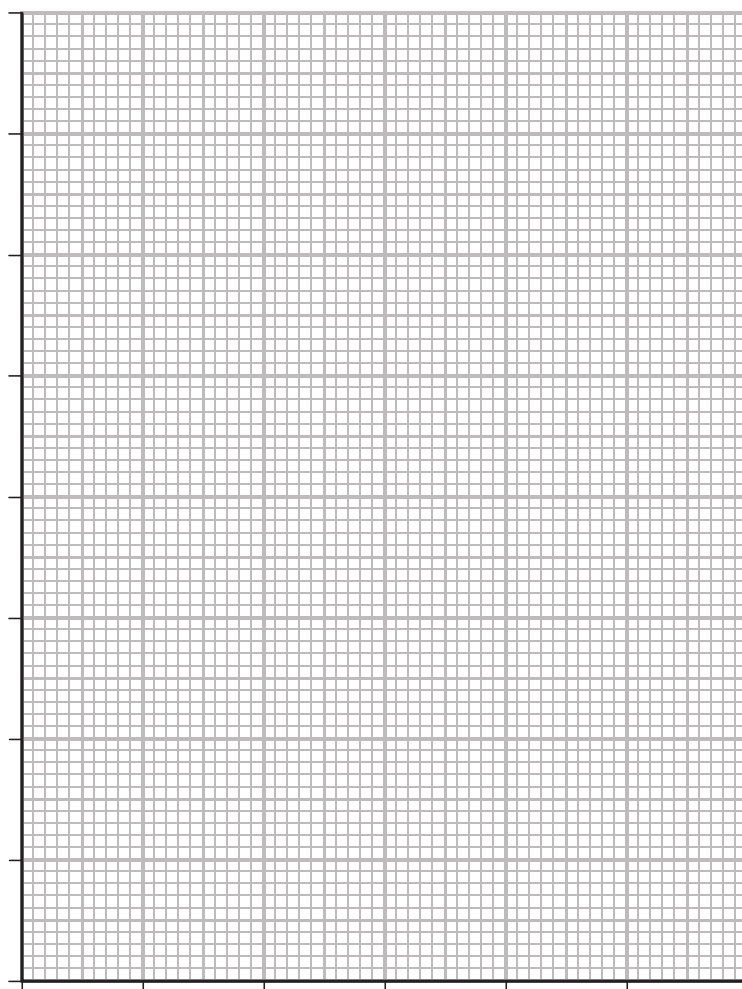

(ii) A student carried out a further experiment using a different mass of magnesium carbonate.

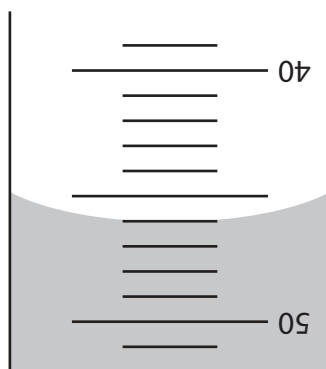

Give the volume of gas collected using the **inverted** measuring cylinder.

(1)

DO NOT WRITE IN THIS AREA

DO NOT WRITE IN THIS AREA

DO NOT WRITE IN THIS AREA



(iii) Determine the mass of magnesium carbonate added in the experiment in (b)(ii), using your graph.

(1)

(iv) Calculate the molar volume of carbon dioxide using your answers to parts (b)(ii) and (b)(iii). Give your value to an appropriate number of significant figures and include units.

[  $A_r$  values: Mg = 24.3 C = 12.0 O = 16.0 ]

(4)

DO NOT WRITE IN THIS AREA

DO NOT WRITE IN THIS AREA

DO NOT WRITE IN THIS AREA



(v) The acid must be in excess for each experiment.

Calculate the **minimum** concentration of hydrochloric acid needed for 30 cm<sup>3</sup> of acid to completely react with 0.25 g of magnesium carbonate.



(2)

(c) The value of molar volume calculated in (b)(iv) was lower than the student expected.

Give **two** reasons for the value being lower than expected.

Assume that the correct amounts of hydrochloric acid and magnesium carbonate were used.

(2)

.....

.....

.....

.....

.....

.....

.....

(Total for Question 21 = 14 marks)

DO NOT WRITE IN THIS AREA

DO NOT WRITE IN THIS AREA

DO NOT WRITE IN THIS AREA



**22** This question is about fuels and polymers.

Used coffee grounds have been suggested as a carbon-neutral fuel to replace some fossil fuels.

(a) (i) Explain why coffee grounds might be considered a carbon-neutral fuel. (2)

.....

.....

.....

.....

.....

.....

(ii) Explain how the use of fossil fuels causes climate change. (2)

.....

.....

.....

.....

.....

.....





(b) Long chain alkanes are not normally used as fuels as they produce soot.

(i) Name another pollutant formed by **incomplete** combustion of alkanes. (1)

(ii) Write the equation for the **complete** combustion of octane.  
State symbols are not required. (2)

(c) Long chain alkanes are converted into smaller, more useful molecules including alkenes.

(i) Name this process. (1)

(ii) Give a test for alkenes, including the positive result. (2)

(d) Alkenes, such as ethene, can be used to make polymers.

(i) Write a balanced equation for the polymerisation of ethene using displayed formulae. (1)



(ii) Bananas produce ethene as they ripen.

Suggest one advantage and one disadvantage of using ripening bananas as a source of ethene for polymer production.

(2)

.....

.....

.....

.....

.....

.....

(e) Burning poly(chloroethene) in an incinerator results in the formation of hydrogen chloride.

(i) State a **hazard** associated with hydrogen chloride.

(1)

.....

.....

(ii) Suggest how the hydrogen chloride could be removed from the waste gases produced in an incinerator.

(1)

.....

.....

.....

.....

**(Total for Question 22 = 15 marks)**



DO NOT WRITE IN THIS AREA

DO NOT WRITE IN THIS AREA

DO NOT WRITE IN THIS AREA

**23** This question is about bonding.

(a) Draw an electron density map for a molecule of oxygen.

(1)

(b) Draw a diagram to show the shape of a water molecule.  
Give the bond angle.

(2)

Bond angle .....



(c) The compound  $\text{POCl}_3$  has a simple molecular structure.

(i) Complete the dot-and-cross diagram for the  $\text{POCl}_3$  molecule.

Use crosses (x) for the phosphorus electrons, dots (●) for the chlorine electrons and circles (o) for the oxygen electrons.

(2)

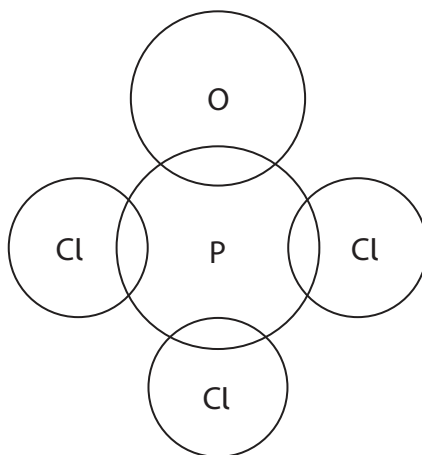

(ii) Explain the shape of this molecule using the electron-pair repulsion theory.

(3)

.....

.....

.....

.....

.....

.....

.....

.....

.....

.....



(d) The properties of metals depend on their structure and bonding.

(i) Draw a labelled diagram to show the metallic bonding in calcium.

(2)

(ii) Explain how the electrical conductivity, high melting temperature and malleability of metals depend on their structure and bonding.

(3)

Electrical conductivity .....

.....  
.....

High melting temperature .....

.....  
.....

Malleability .....

.....  
.....



(e) Diamond, graphite and graphene are all forms of carbon.

- (i) Explain **two** ways in which the physical properties of diamond and graphite differ. Refer to their structure and bonding in your answer.

(4)

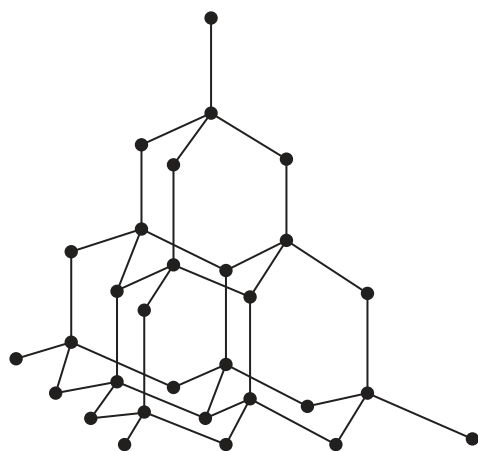

diamond

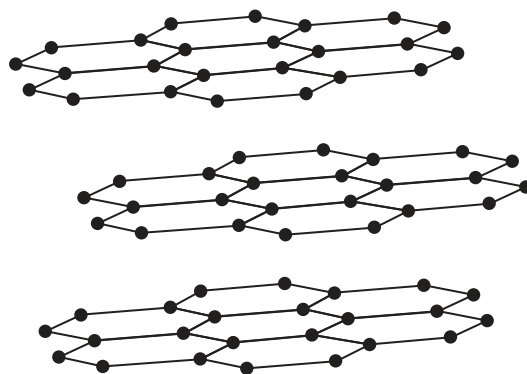

graphite

.....

.....

.....

.....

.....

.....

.....

.....

.....

- (ii) State how the structure of graphene is related to the structure of graphite.

(1)

.....

.....



(iii) State a use for graphene, identifying the property that makes it suitable for that use. (2)

.....

.....

.....

.....

**(Total for Question 23 = 20 marks)**

DO NOT WRITE IN THIS AREA

DO NOT WRITE IN THIS AREA

DO NOT WRITE IN THIS AREA



24 Airbags protect occupants by inflating when a car crashes.

Airbags rely on chemical reactions to produce large volumes of gases quickly. In some airbags, solid sodium azide ( $\text{NaN}_3$ ) decomposes forming nitrogen gas and sodium as the only products.

- (a) Write an equation for the decomposition of sodium azide.  
State symbols are not required.

(1)

- (b) A passenger airbag requires  $120 \text{ dm}^3$  of gas to fill it.

Calculate, using the ideal gas equation, the mass of sodium azide required to fill a passenger airbag in this reaction under standard conditions ( $101\,000 \text{ Pa}$ ,  $25^\circ\text{C}$ ).

Give your answer to an appropriate number of significant figures.

$$[pV = nRT \quad R = 8.31 \text{ JK}^{-1} \text{ mol}^{-1}]$$

(6)





DO NOT WRITE IN THIS AREA

DO NOT WRITE IN THIS AREA

DO NOT WRITE IN THIS AREA

(c) Two further reactions take place in the airbag.

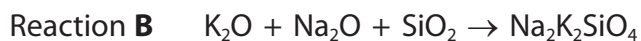

(i) Reaction **A** produces more nitrogen to inflate the airbag.

Calculate the atom economy, by mass, for the production of nitrogen in reaction **A**.

Give your answer to an appropriate number of significant figures.

(3)

(ii) State the type of reaction taking place in reaction **B**.

(1)

---

(Total for Question 24 = 11 marks)

---

**TOTAL FOR SECTION B = 60 MARKS**  
**TOTAL FOR PAPER = 80 MARKS**



DO NOT WRITE IN THIS AREA

DO NOT WRITE IN THIS AREA

DO NOT WRITE IN THIS AREA

**BLANK PAGE**



DO NOT WRITE IN THIS AREA

DO NOT WRITE IN THIS AREA

DO NOT WRITE IN THIS AREA

**BLANK PAGE**



# The Periodic Table of Elements

1		2		3								4		5		6		7		0 (8)																					
(1)		(2)		(3)		(4)		(5)		(6)		(7)		(8)		(9)		(10)		(11)		(12)		(13)		(14)		(15)		(16)		(17)		(18)							
6.9 <b>Li</b> lithium 3		9.0 <b>Be</b> beryllium 4		45.0 <b>Sc</b> scandium 21		47.9 <b>Ti</b> titanium 22		50.9 <b>V</b> vanadium 23		52.0 <b>Cr</b> chromium 24		54.9 <b>Mn</b> manganese 25		55.8 <b>Fe</b> iron 26		58.9 <b>Co</b> cobalt 27		58.7 <b>Ni</b> nickel 28		63.5 <b>Cu</b> copper 29		65.4 <b>Zn</b> zinc 30		69.7 <b>Ga</b> gallium 31		72.6 <b>Ge</b> germanium 32		74.9 <b>As</b> arsenic 33		79.0 <b>Se</b> selenium 34		83.8 <b>Kr</b> krypton 36									
23.0 <b>Na</b> sodium 11		24.3 <b>Mg</b> magnesium 12		88.9 <b>Y</b> yttrium 39		91.2 <b>Zr</b> zirconium 40		92.9 <b>Nb</b> niobium 41		95.9 <b>Mo</b> molybdenum 42		[98] <b>Tc</b> technetium 43		101.1 <b>Ru</b> ruthenium 44		102.9 <b>Rh</b> rhodium 45		106.4 <b>Pd</b> palladium 46		107.9 <b>Ag</b> silver 47		112.4 <b>Cd</b> cadmium 48		114.8 <b>In</b> indium 49		118.7 <b>Sn</b> tin 50		121.8 <b>Sb</b> antimony 51		126.9 <b>Te</b> tellurium 52		131.3 <b>Xe</b> xenon 54									
132.9 <b>Cs</b> caesium 55		137.3 <b>Ba</b> barium 56		138.9 <b>La*</b> lanthanum 57		178.5 <b>Hf</b> hafnium 72		180.9 <b>Ta</b> tantalum 73		183.8 <b>W</b> tungsten 74		186.2 <b>Re</b> rhenium 75		190.2 <b>Os</b> osmium 76		192.2 <b>Ir</b> iridium 77		195.1 <b>Pt</b> platinum 78		197.0 <b>Au</b> gold 79		200.6 <b>Hg</b> mercury 80		204.4 <b>Tl</b> thallium 81		207.2 <b>Pb</b> lead 82		209.0 <b>Bi</b> bismuth 83		[210] <b>At</b> astatine 85		[222] <b>Rn</b> radon 86									
[223] <b>Fr</b> francium 87		[226] <b>Ra</b> radium 88		[227] <b>Ac*</b> actinium 89		[261] <b>Rf</b> rutherfordium 104		[262] <b>Db</b> dubnium 105		[266] <b>Sg</b> seaborgium 106		[264] <b>Bh</b> bohrium 107		[277] <b>Hs</b> hassium 108		[268] <b>Mt</b> meitnerium 109		[271] <b>Ds</b> darmstadtium 110		[272] <b>Rg</b> roentgenium 111		Elements with atomic numbers 112-116 have been reported but not fully authenticated																			

\* Lanthanide series

\* Actinide series

140 <b>Ce</b> cerium 58	141 <b>Pr</b> praseodymium 59	144 <b>Nd</b> neodymium 60	[147] <b>Pm</b> promethium 61	150 <b>Sm</b> samarium 62	152 <b>Eu</b> europium 63	157 <b>Gd</b> gadolinium 64	159 <b>Tb</b> terbium 65	163 <b>Dy</b> dysprosium 66	165 <b>Ho</b> holmium 67	167 <b>Er</b> erbium 68	169 <b>Tm</b> thulium 69	173 <b>Yb</b> ytterbium 70	175 <b>Lu</b> lutetium 71
232 <b>Th</b> thorium 90	[231] <b>Pa</b> protactinium 91	238 <b>U</b> uranium 92	[237] <b>Np</b> neptunium 93	[242] <b>Pu</b> plutonium 94	[243] <b>Am</b> americium 95	[247] <b>Cm</b> curium 96	[245] <b>Bk</b> berkelium 97	[251] <b>Cf</b> californium 98	[254] <b>Es</b> einsteinium 99	[253] <b>Fm</b> fermium 100	[256] <b>Md</b> mendelevium 101	[254] <b>No</b> nobelium 102	[257] <b>Lr</b> lawrencium 103

DO NOT WRITE IN THIS AREA

DO NOT WRITE IN THIS AREA

DO NOT WRITE IN THIS AREA

